

150 PSIG

SINGLE AND MULTI-PLY STAINLESS STEEL EXPANSION JOINT BELLOWS

321 S.S. Bellows with Welding Aide

U. S. BELLOWS, INC.®

Monel and Inconel available on request.

A DIVISION OF PIPING TECHNOLOGY & PRODUCTS, INC.

Notes:

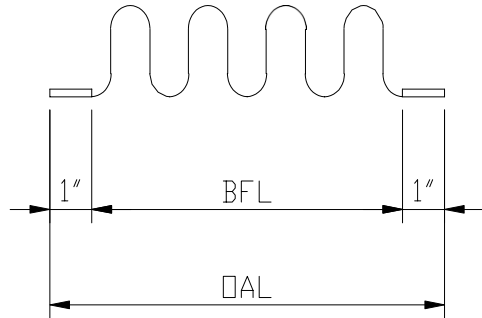

1. Pressure Range: Vacuum to 150 PSIG.
2. Temperature Range: -20 F to 800 F.
3. Rated cycle life is 3000 cycles per EJMA for any one tabulated movement.
4. Maximum axial extension movement is 50% of the tabulated axial movement.
5. Rated extension movement is equal to rated axial movement provided the bellows is pre-compressed the amount of design extension.
6. Maximum test pressure: 1.5x design pressure
7. Materials: -- Bellows : ASTM A240-T321SS
-- Welding Aides : ASTM A240-T321SS
8. Flanges or welds ends can be attached to the bellows 1/16" thk (min.) Welding aide.
9. For more details request PT&P's Expansion Joint Catalog.

ND in.	Part Number	Max. Axial Movement in.	Max. Lateral Movement in.	Max. Angular Movement Deg.	B.F.L. in.	Number of Corrugations	O.A.L. in.	Weight Each lbs.	Axial Spring Rate lbs./in	Lateral Spring Rate lbs./in.	Angular Spring Rate in/lbs/deg.
3/4	S007150C	0.33	0.14	10	1.63	7	2.38	0.06	734	633	13
	L007150C	0.47	0.25	10	2.19	10	2.94	0.07	510	218	13
1	S010150C	0.39	0.12	10	1.56	6	2.31	0.08	582	930	13
	L010150C	0.53	0.19	10	1.94	8	2.69	0.09	437	392	13
1 1/2	S015150C	0.41	0.10	10	1.75	7	2.50	0.13	739	1815	13
	L015150C	0.59	0.19	10	2.38	10	3.13	0.15	515	622	13
2	US-2-8-150S	0.34	0.12	10	3.00	8	5.00	0.60	2911	3153	41
	US-2-12-150L	0.51	0.28	10	4.50	12	6.50	1.00	1940	934	28
2 1/2	US-2.5-8-150S	0.69	0.20	10	3.00	8	5.00	1.00	1441	2615	53
	US-2.5-12-150L	0.78	0.34	10	4.50	12	6.50	1.00	961	775	35
3	US-3-8-150S	0.66	0.16	10	3.00	8	5.00	1.00	950	2281	30
	US-3-12-150L	0.82	0.31	10	4.50	12	6.50	1.00	974	1007	30
4	US-4-8-150S	0.70	0.13	10	3.00	8	5.00	1.00	1224	4822	63
	US-4-12-150L	1.05	0.30	10	4.50	12	6.50	2.00	816	1429	42
5	US-5-8-150S	0.69	0.11	10	3.00	8	5.00	2.00	1531	8791	115
	US-5-12-150L	1.03	0.25	10	4.50	12	6.50	3.00	1021	2605	77
6	US-6-8-150S	0.83	0.15	10	4.00	8	6.00	3.00	1823	8364	195
	US-6-12-150L	1.25	0.34	10	6.00	12	8.00	4.00	1215	2478	130
8	US-8-8-150S	0.81	0.11	10	4.00	8	6.00	5.00	2401	17807	414
	US-8-12-150L	1.22	0.26	10	6.00	12	8.00	7.00	1601	5276	276
10	US-10-8-150S	1.48	0.33	10	8.00	8	10.00	11.00	2985	8692	809
	US-10-12-150L	2.22	0.75	10	12.00	12	14.00	17.00	1990	2575	539
12	US-12-8-150S	1.54	0.29	10	8.00	8	10.00	20.00	3532	14601	1359
	US-12-12-150L	2.31	0.66	10	12.00	12	14.00	29.00	2354	4326	906
14	US-14-8-150S	1.53	0.26	10	8.00	8	10.00	23.00	3894	19100	1778
	US-14-12-150L	2.30	0.60	10	12.00	12	14.00	31.00	2596	5659	1185
16	US-16-8-150S	1.52	0.23	10	8.00	8	10.00	25.00	4473	28074	2613
	US-16-12-150L	2.28	0.52	10	12.00	12	14.00	36.00	2982	8318	1742
18	US-18-8-150S	1.50	0.20	9	8.00	8	10.00	29.00	5052	39491	3676
	US-18-12-150L	2.26	0.47	10	12.00	12	14.00	40.00	3368	11701	2451
20	US-20-8-150S	1.49	0.18	8	8.00	8	10.00	32.00	5632	53644	4993
	US-20-12-150L	2.24	0.42	10	12.00	12	14.00	45.00	3755	15895	3329
22	US-22-8-150S	1.49	0.17	8	8.00	8	10.00	32.00	4132	52913	7578
	US-22-12-150L	2.23	0.38	10	12.00	12	14.00	45.00	2755	15678	5052
24	US-24-8-150S	1.47	0.11	5	8.00	8	10.00	39.00	6792	91337	8502
	US-24-12-150L	2.21	0.26	8	12.00	12	14.00	54.00	4528	27063	5668

36" PRESSURE BALANCED EXP. JT. RATED FOR 150 P.S.I.



REV.1-4/23/99

72" DIAMETER THIN WALL DUCT EXP. JT. RATED FOR 50 P.S.I.



176

10" DIAMETER MULTI-BELLOWS EXP. JOINT



150psig.wk4-12/8/94